

# 01. BUSHING PARTS 軸受関係

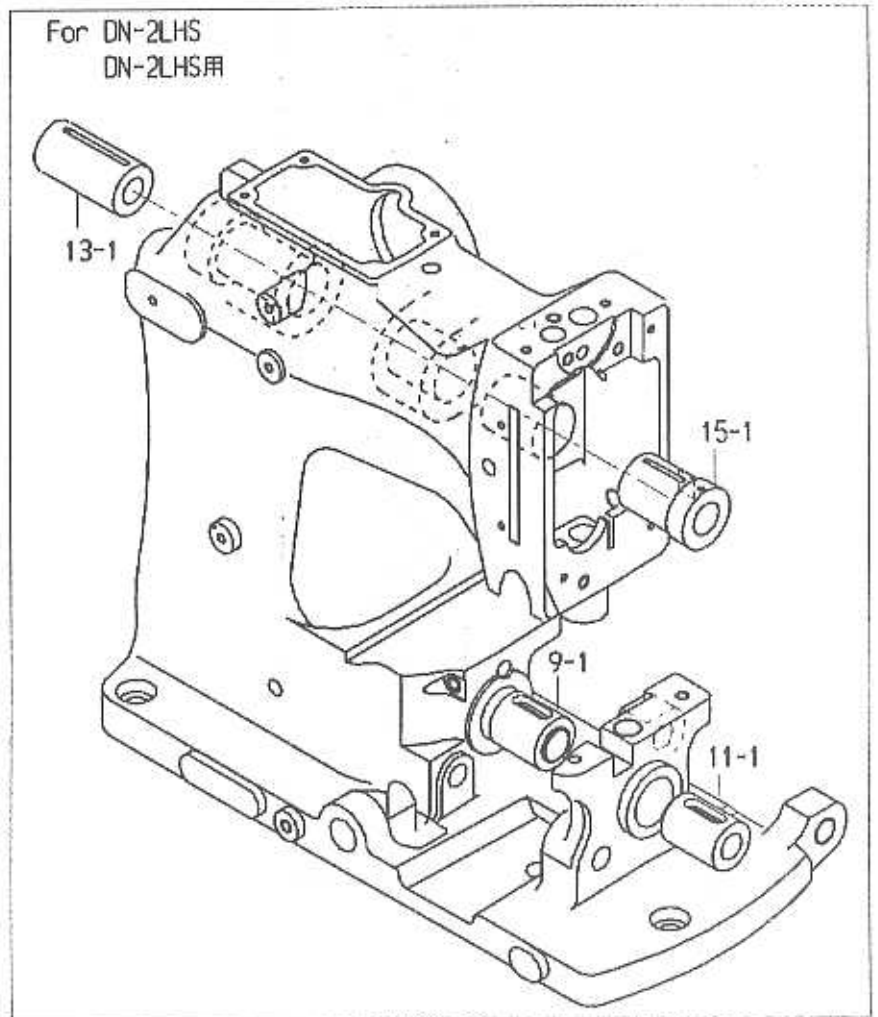
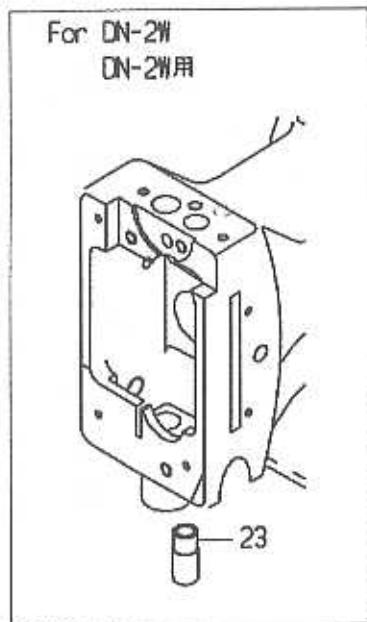
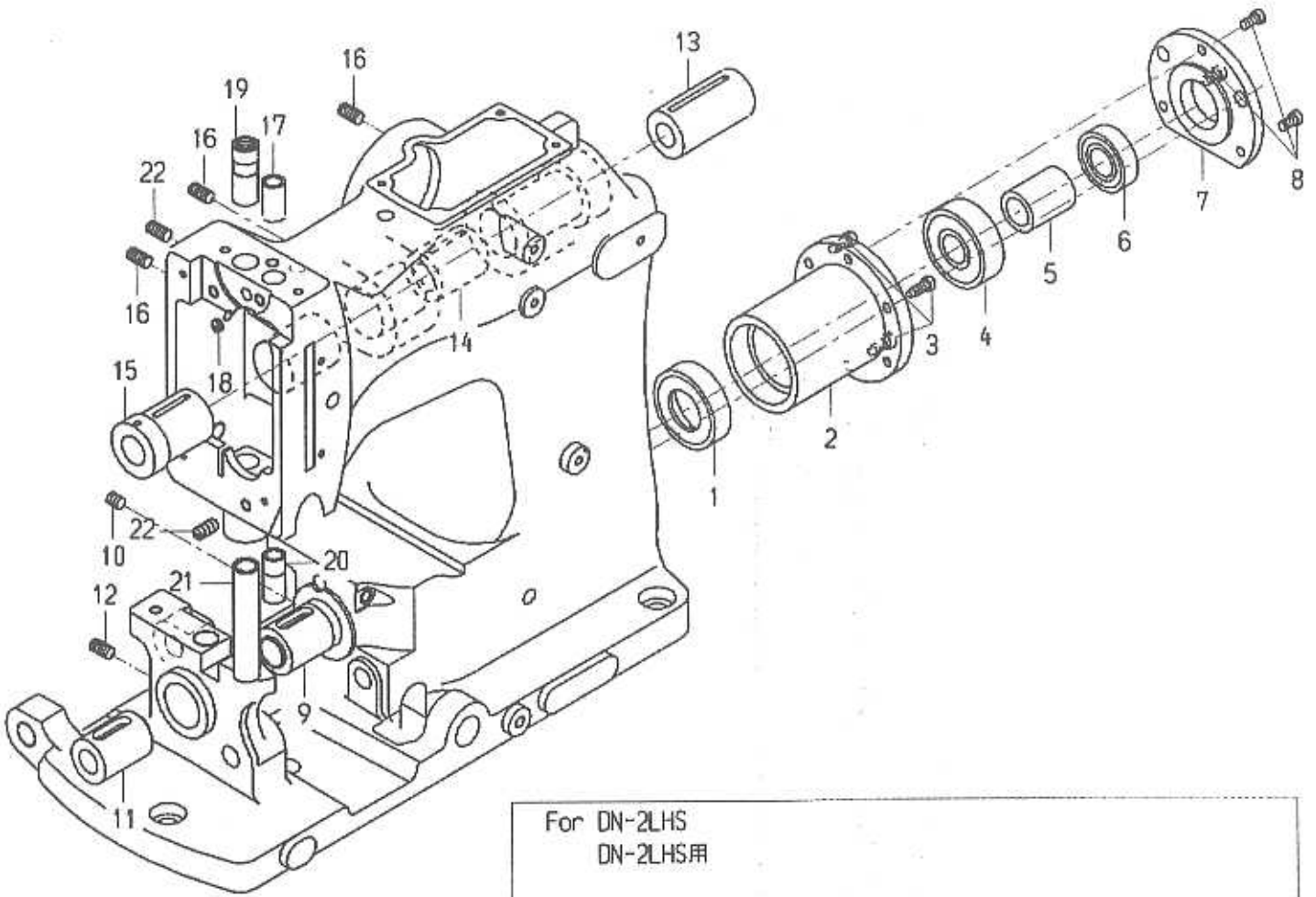

## 01. BUSHING PARTS

## 軸受関係

図番 Ref. No.	部品番号 Part No.	部品名称 Description	個数 Q'ty			摘要 Remarks
			DN-2HS	DN-2LHS	DN-2W	
1	D04003	Oil Seal (SC224211)				
2	031082	Crank Shaft Bushing Housing				
3	3/16S28017	Screw for 031082				
4	1A01004	Ball Bearing (6202ZZ)				
5	031111	Collar A				
6	1A01002	Ball Bearing (6302ZZ)				
7	031091	Bearing Holder				
8	3/16S28014	Screw for 031091				
9	031073	Crank Shaft Bushing, middle				
9-1	041033	Crank Shaft Bushing, middle				
10	15/64S28513	Screw for 031073,041033				
11	031063	Crank Shaft Bushing, front				
11-1	041043	Crank Shaft Bushing, front				
12	15/64S28516	Screw for 031063,041043				
13	032081	Arm Rocker Shaft Bushing, rear				
13-1	042031	Arm Rocker Shaft Bushing, rear				
14	032071	Arm Rocker Shaft Bushing, middle				
15	032061	Arm Rocker Shaft Bushing, front				
15-1	042021	Arm Rocker Shaft Bushing, front				
16	15/64S28516	Screw for 032081,042031,032071 032061,042021				
17	032151	Needle Bar Bushing, upper				
18	15/64S28501	Screw for 032151				
19	032201	Presser Bar Bushing, upper				
20	032161	Needle Bar Bushing, lower				
21	032211	Presser Bar Bushing, lower				
22	15/64S28516	Screw for 032161,032201,092062				
23	092062	Needle Bar Bushing, lower				

## 02. OILING PARTS 給油関係

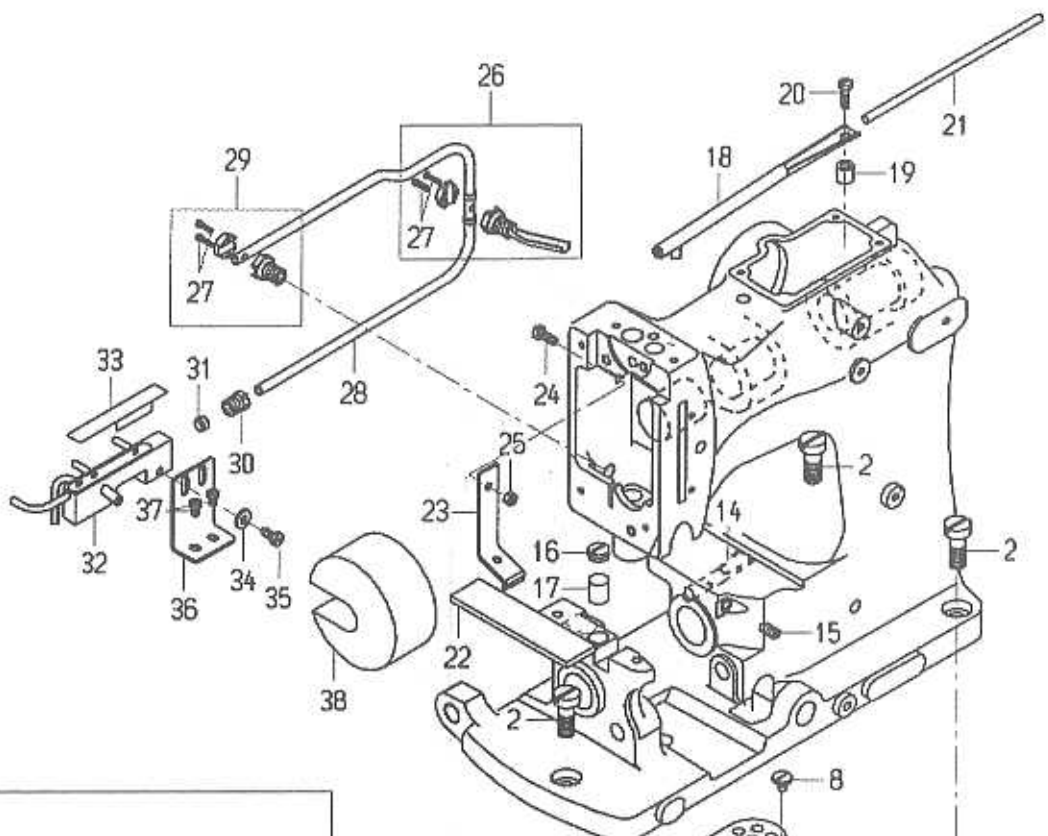

For DN-2LHS  
DN-2LHS用

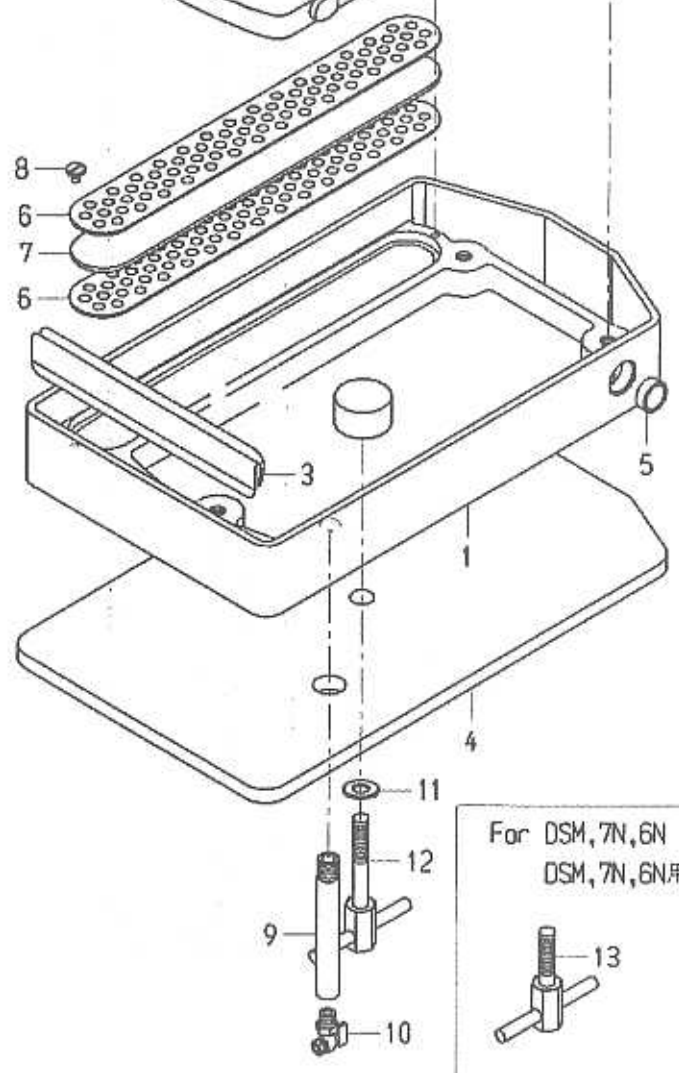
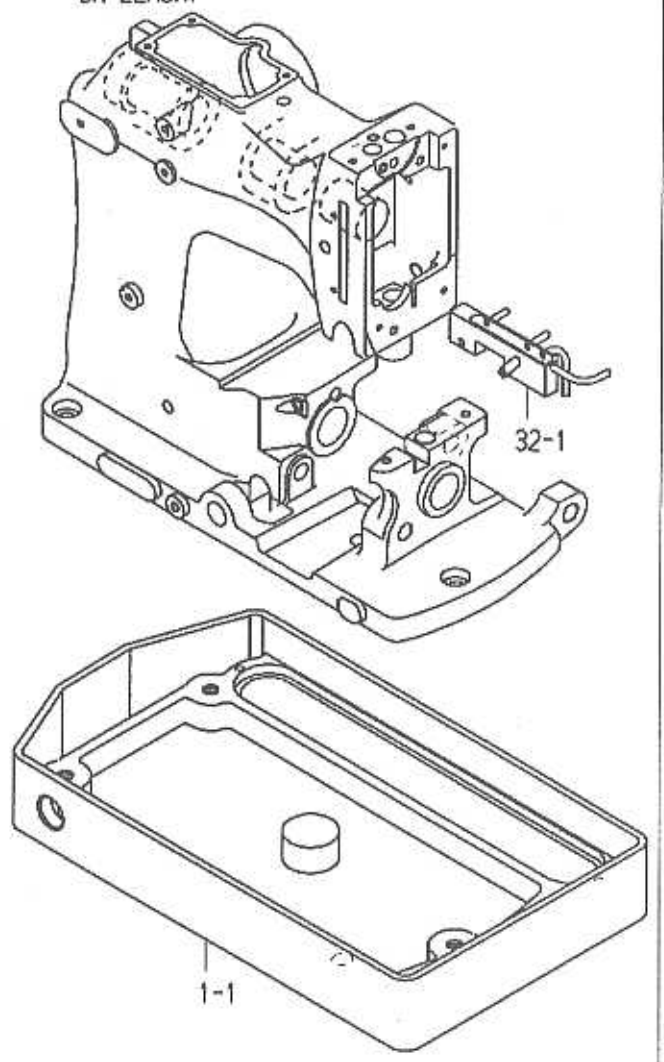

For DSM, 7N, 6N  
DSM, 7N, 6N用



## 02. OILING PARTS 給油関係

図番 Ref. No.	部品番号 Part No.	部品名称 Description	個数 Q'ty			摘要 Remarks
			DN-2HS	DN-2LHS	DN-2W	
1	035251	Oil Pan	1	-	1	
1-1	045071	Oil Pan	-	1	-	
2	W3/8S16001	Screw for 035251,045071	3	3	3	
3	035302	Dust Cover	1	1	1	
4	035741	Rubber Pad	1	1	1	
5	D05002	Oil Gauge (HL VA-01)	1	1	1	
6	035282	Oil Filter Cover	2	2	2	
7	035291	Oil Filter	1	1	1	
8	3/16S32023	Screw for 035281	2	2	2	
9	015151	Oil Pipe	1	1	1	
10	D06001	Cock (PF1/8)	1	1	1	
11	2W10	Washer for 015141,015142	1	1	1	
12	015141	Oil Pan Fixing Screw	1	-	1	
13	015142	Oil Pan Fixing Screw	(1)	1	-	for DSM, 7N, 6N
14	035381	Oil Pipe	1	1	1	
15	15/64S28516	Screw for 035381	1	1	1	
16	1/2S24501	Screw	1	1	1	
17	035721	Felt	1	1	1	
18	035921	Oil Pipe	1	1	1	
19	182271	Collar	1	1	1	
20	11/64S40072	Screw for 035921	1	1	1	
21	035931	Felt	1	1	1	
22	035651	Felt	1	1	1	
23	035271	Holder	1	1	1	
24	11/64S40010	Screw for 035271	1	1	1	
25	11/64N40201	Nut for 035271	1	1	1	
26	035321A	Coupling and Oil Pipe	1	1	1	(27)
27	3/32S56006	Screw for 035321A, 035321	4	4	4	
28	035312	Oil Pipe	1	1	1	
29	035321	Coupling	1	1	1	(27)
30	D07006	Compression Bushing (M6252-6)	1	1	1	
31	D07008	Compression Sleeve (M6254-6)	1	1	1	
32	035631	Oiler	1	-	1	
32-1	045161	Oiler	-	1	-	
33	035661	Cover	1	1	1	
34	11/64W15103	Washer	1	1	1	
35	11/64S40009	Screw	1	1	1	
36	0354343	Cover	1	1	1	
37	11/64S40005	Screw	2	2	2	
38	035821	Fence	1	1	1	

### 03. MISCELLANEOUS COVER PARTS

カバー関係

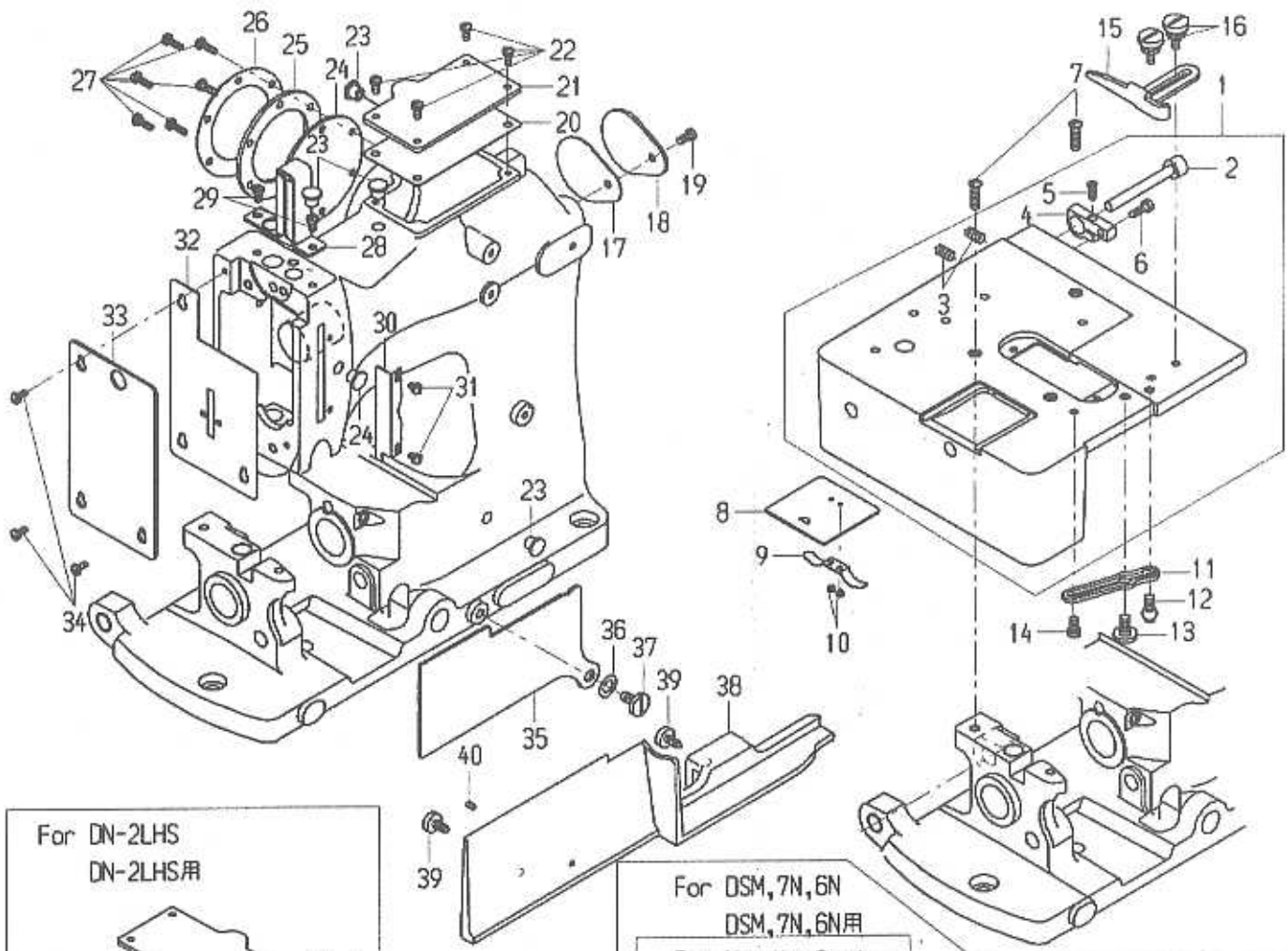

For DN-2LHS  
DN-2LHS用

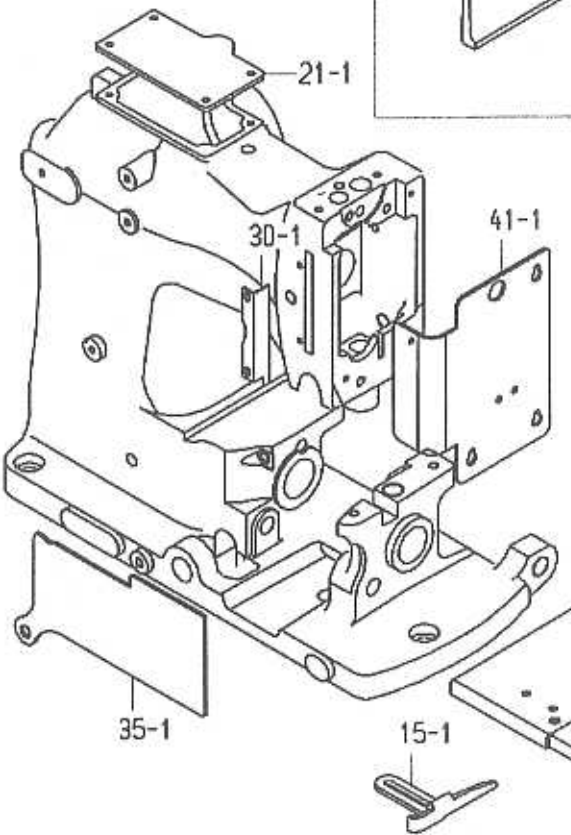

For DSM, 7N, 6N  
DSM, 7N, 6N用

For Needle Cooler  
ニードルクーラー用

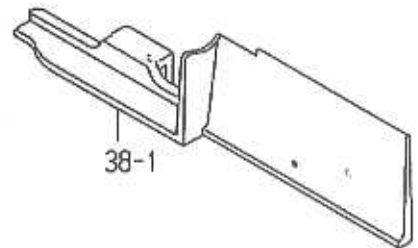
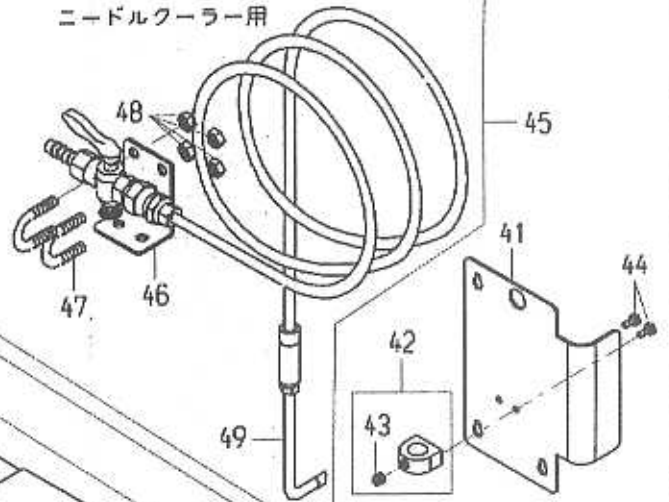

## 03. MISCELLANEOUS COVER PARTS

## カバー関係

図番 Ref. No.	部品番号 Part No.	部品名称 Description	個数 Q'ty			摘要 Remarks
			DN-2HS	DN-2LHS	DN-2W	
1	035111A	Cloth Plate Ass'y	1	-	1	(2~6)
1-1	045051A	Cloth Plate Ass'y	-	1	-	(2~6)
2	035141	Pin	1	1	1	
3	15/64S28516	Screw for 035141	2	2	2	
4	035131	Cloth Plate Extension Hinge Stud Bearing	1	1	1	
5	9/64S40003	Screw for 035131	1	1	1	
6	11/64S40008	Screw for 035131	1	1	1	
7	7/32S32007	Screw for 035111A,045051A	3	3	3	
8	015081	Cloth Plate Slide	1	1	1	
9	015091	Spring	1	1	1	
10	3/32S56008	Screw for 015091	2	2	2	
11	035151	Stopper Spring	1	1	1	
12	15/64S28018	Screw	1	1	1	
13	15/64S28017	Screw	1	1	1	
14	3/16S32028	Screw	1	1	1	
15	015111	Guide	1	-	1	
15-1	025031	Guide	-	1	-	
16	3/16S32004	Screw for 015111	2	2	2	
17	035232	Gasket	1	1	1	
18	035222	Rear Cover	1	1	1	
19	11/64S40006	Screw for 035222	1	1	1	
20	035491	Gasket	1	1	1	
21	035481	Top Cover	1	-	1	
21-1	035481L	Top Cover	-	1	-	
22	9/64S40005	Screw for 035481	2	2	2	
23	065401	Rubber Bushing	7	7	7	
24	035211	Gasket	1	1	1	
25	035191	Side Cover	1	1	1	
26	035201	Side Cover Retainer	1	1	1	
27	9/64S40035	Screw for 035201	6	6	6	
28	035941	Needle Bar Cover	1	1	1	
29	11/64S40005	Screw for 035342,035941	2	2	2	
30	035911	Cover	1	-	1	
30-1	045191	Cover	-	1	-	
31	9/64S40004	Screw for 035911,045191	2	2	2	
32	035181	Gasket	1	1	1	
33	035171	Face Plate	1	-	1	
34	9/64S40005	Screw for 035171,035952,045122	3	3	3	
35	035241	Side Cover	1	-	1	
35-1	035241L	Side Cover	-	1	-	
36	5/16W05201	Washer for 035241	1	1	1	
37	15/64S28017	Screw for 035241	1	1	1	
38	035261	Oil Filter Cover	1	-	1	
38-1	045081	Oil Filter Cover	-	1	-	
39	3/16S32024	Screw for 035261,045081	2	2	2	
40	9/64S40502	Screw for 035261,045081	2	2	2	
41	035952	Face Plate	(1)	-	-	
41-1	045122	Face Plate	-	1	-	
42	035691	Holder	(1)	1	-	(43)
43	15/64S28511	Screw for 035691	(1)	1	-	
44	9/64S40005	Screw for 035691	(2)	2	-	
45	035642A	Needle Cooler Ass'y	(1)	1	-	for DSM,7N,6N
46	035831	Base Holder	(1)	1	-	
47	E01001	U-Bolt (W1/4)	(2)	2	-	
48	1NW1/4	Nut	(4)	4	-	
49	035642	Nozzle	1	1	-	

# 04.THREAD TENSION PARTS

糸調子関係

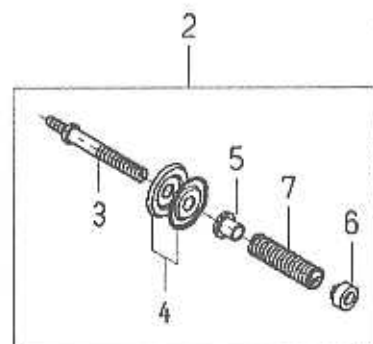
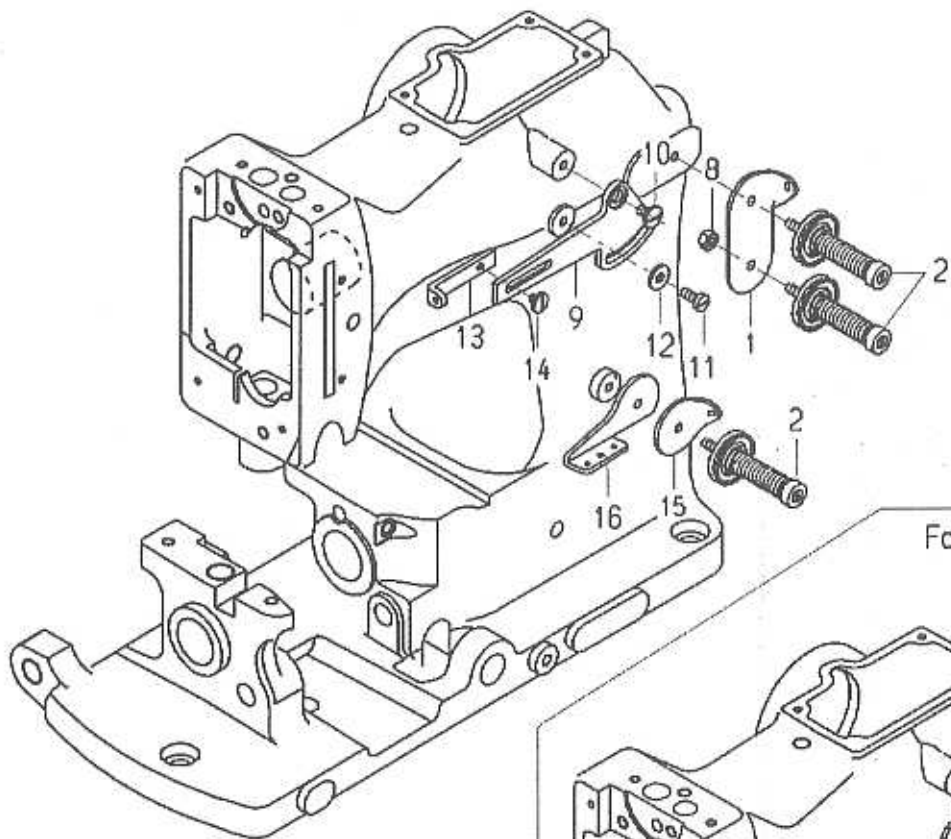

For DN-2W  
DN-2W用

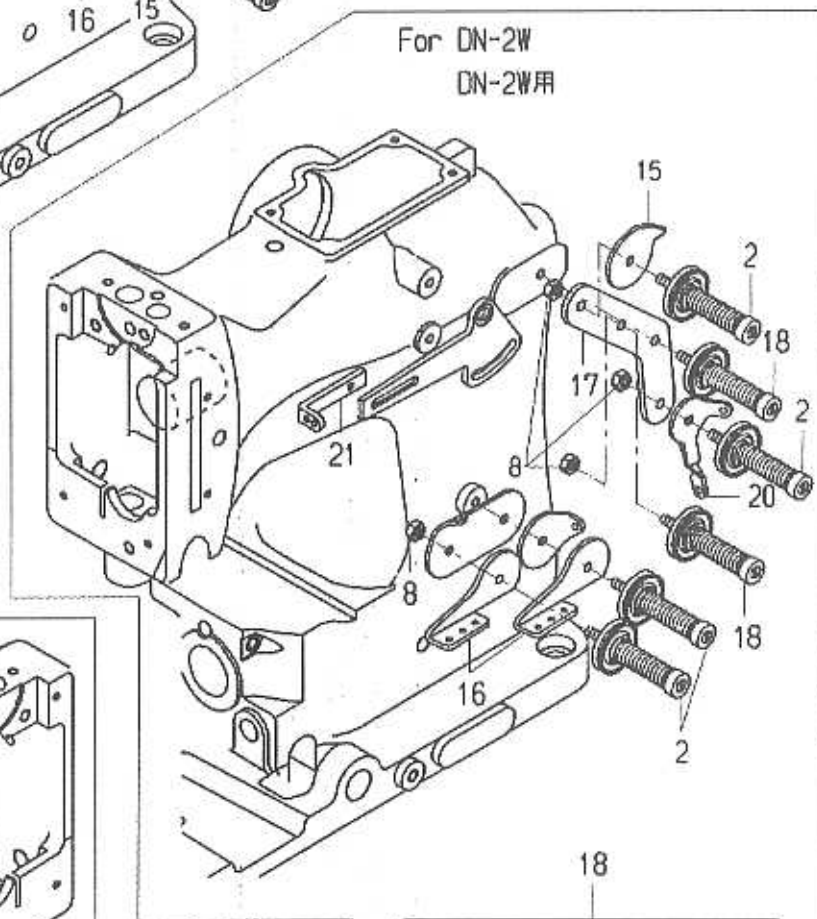

For DN-2LHS  
DN-2LHS用

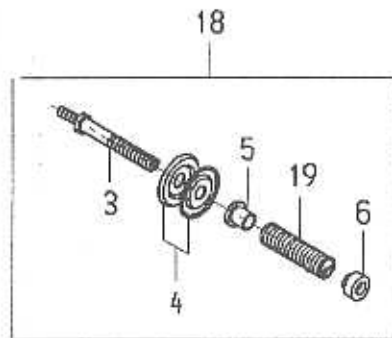
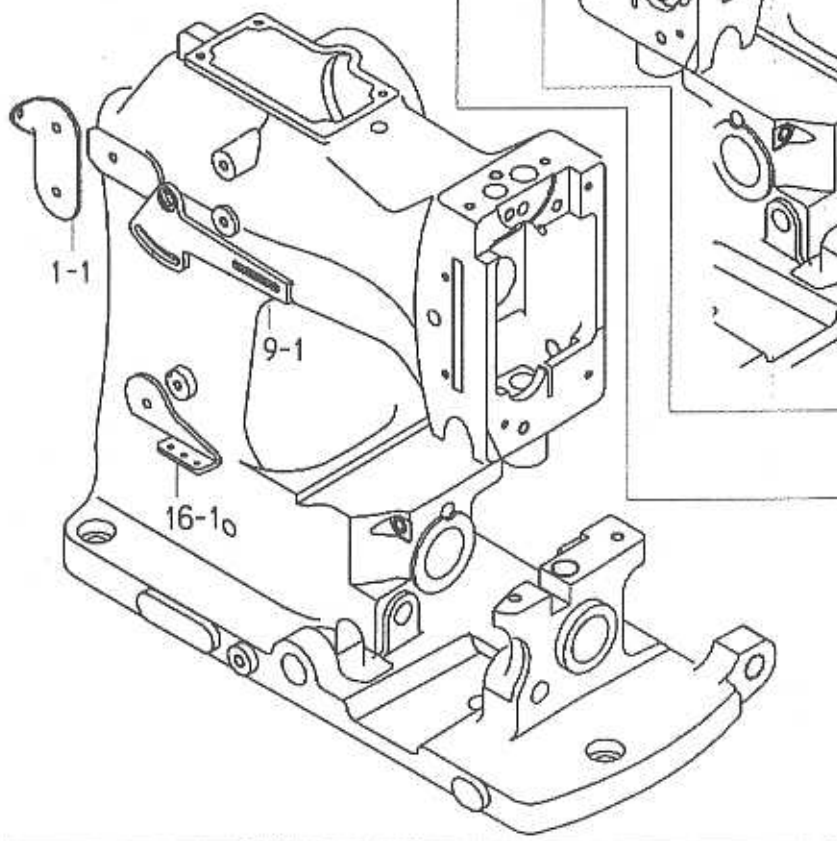

# 04. THREAD TENSION PARTS

## 糸調子関係

図番 Ref. No.	部品番号 Part No.	部品名称 Description	個数 Q'ty			摘要 Remarks	
			DN-2HS	DN-2LHS	DN-3W		
1	035011	Tension Thread Guide	糸ガイド座金	1	-	1	
1-1	045011	Tension Thread Guide	糸ガイド座金	-	1	-	
2	035021A	Thread Tension Ass'y	糸調子組	3	3	4	(3-7)
3	035021	Tension Post	糸調子芯棒	3	3	6	
4	065261	Tension Disc	糸調子皿	6	6	12	
5	035071	Tension Post Ferrule	スプリングシート	3	3	6	
6	065171	Tension Nut	糸調子ナット	3	3	4	
7	035061	Tension Spring	糸調子スプリング	3	3	6	
8	11/64N40104	Nut for 035021A,035021B	ナット	1	1	4	
9	035031	Needle Thread Controller A	上糸調節A	1	-	1	
9-1	045021	Needle Thread Controller A	上糸調節A	-	1	-	
10	11/64S40014	Screw for 035031,045021	ネジ	1	1	1	
11	11/64S40009	Screw for 035031,045021	ネジ	1	1	1	
12	11/64W15103	Washer for 035031,045021	ワッシャー	1	1	1	
13	035042	Needle Thread Controller B	上糸調節B	1	1	-	
14	9/64S40011	Screw for 035042,035043	ネジ	1	1	1	
15	015011	Tension Thread Guide	糸ガイド座金	1	1	2	
16	035083	Looper Thread Controller	下糸調節ガイド	1	-	2	
16-1	045032	Looper Thread Controller	下糸調節ガイド	-	1	-	
17	035881	Needle Thread Tension Base	上糸調子ベース	-	-	1	
18	035021B	Thread Tension Ass'y	糸調子組	-	-	2	(3-6.19)
19	035062	Tension Spring	糸調子スプリング	-	-	2	
20	035402	Looper Thread Guide	下糸ガイド	-	-	1	
21	035043	Needle Thread Controller B	上糸調節B	-	-	1	



# 05. CRANK SHAFT AND ARM ROCKER SHAFT

## クランクシャフト、上軸関係

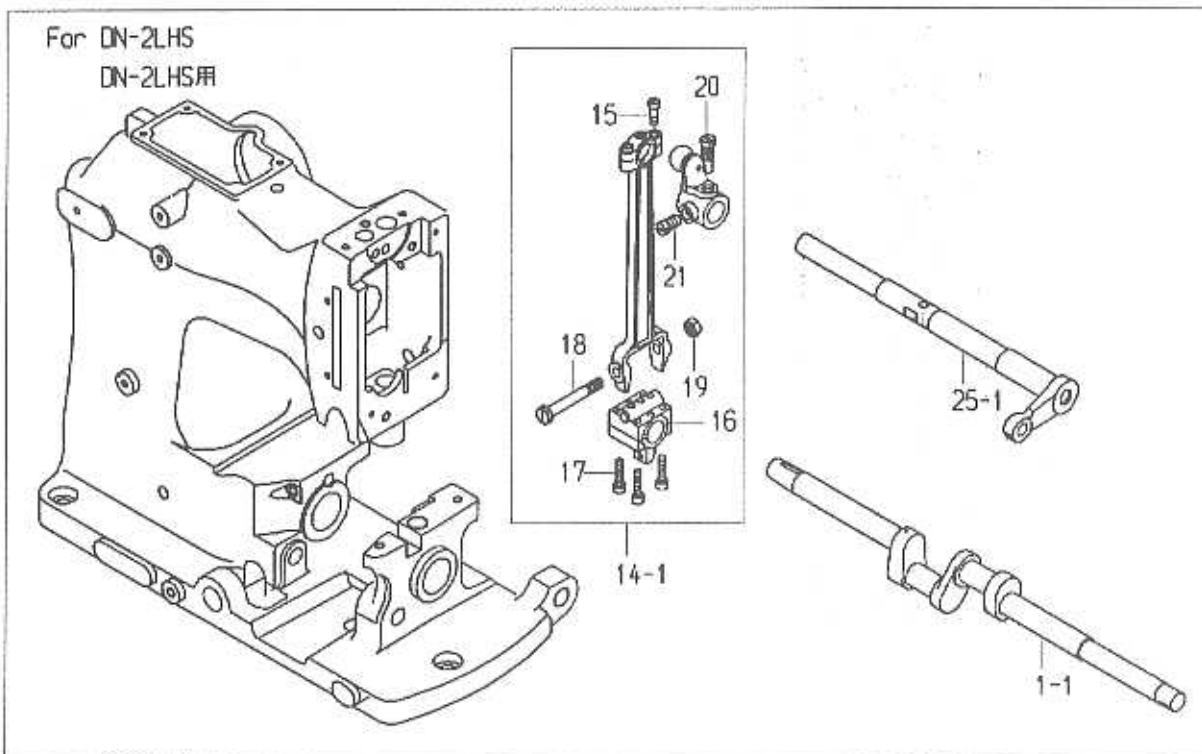
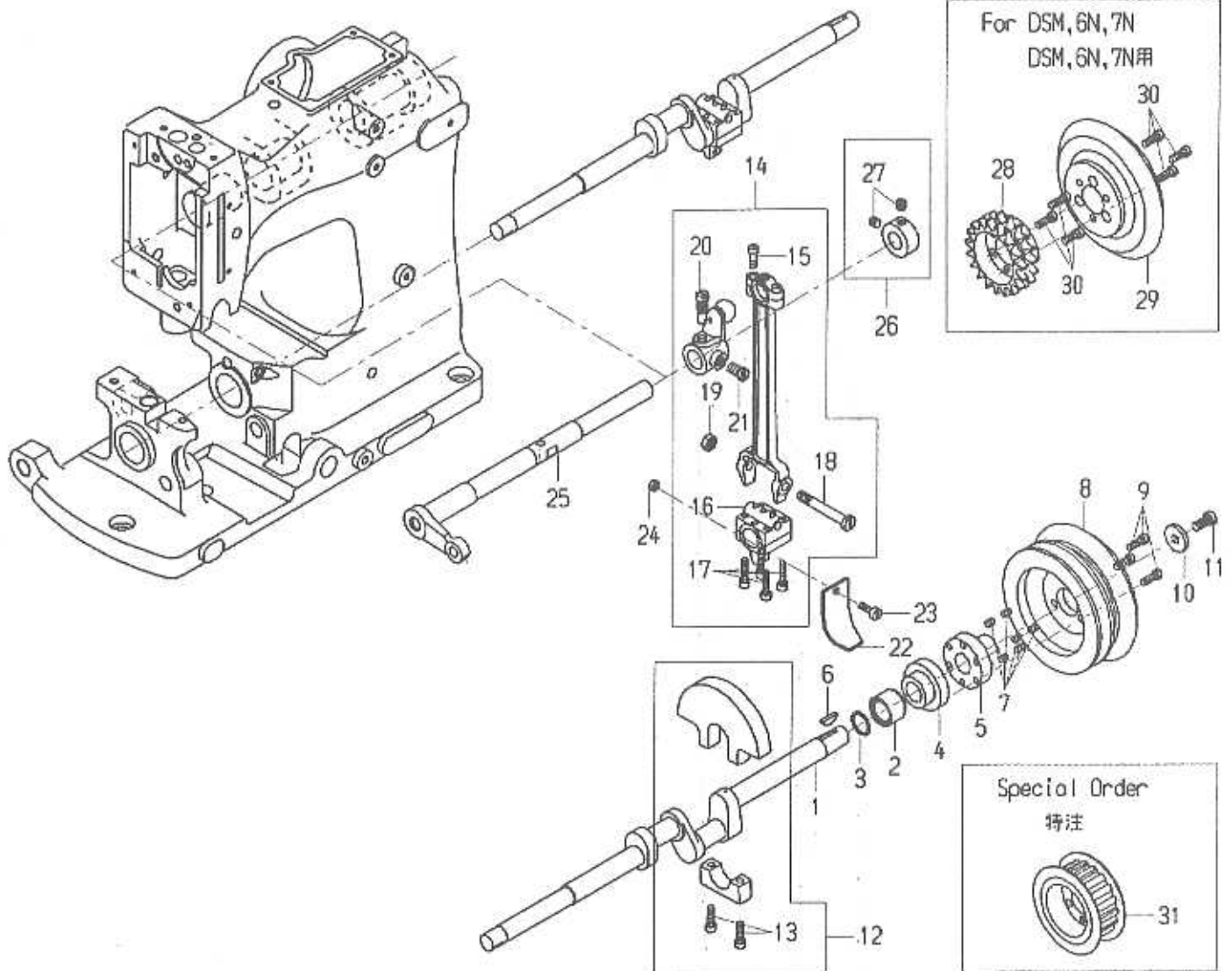

# 05. CRANK SHAFT AND ARM ROCKER SHAFT

## クランクシャフト、上軸関係

図番 Ref. No.	部品番号 Part No.	部品名称 Description	個数 Q'ty			摘要 Remarks	
			DN-2HS	DN-2LHS	DN-2W		
1	031025	Crank Shaft	クランクシャフト	1	-	1	
1-1	041024	Crank Shaft	クランクシャフト	-	1	-	
2	031201	Bearing Holder Collar B	カラーB	1	1	1	
3	31L1015	"O"Ring	"O"リング	1	1	1	
4	031141	Stopper Collar	ストップカラー	1	1	1	
5	031151	Pulley Holder	プーリー軸	1	1	1	
6	2K3×16	Key for 031151 (3×16)	半月キー (3×16)	1	1	1	
7	11/64S40504	Screw	ネジ	6	6	6	
8	031181	Pulley	プーリー	1	(1)	1	
9	3/16S28005	Screw for 031181	ネジ	3	3	3	
10	15/64W30102	Washer for 031181	ワッシャー	1	1	1	
11	15/64S28021	Screw for 031181	ネジ	1	1	1	
12	031131	Balance Weight	バランスウェイト	1	1	1	
13	3/16S28018	Screw for 031131	ネジ	2	2	2	
14	032012A	Crank Shaft Connecting Rod Ass'y	立ロッド組	1	-	1	(15-21)
14-1	032012B	Crank Shaft Connecting Rod Ass'y	立ロッド組	-	1	-	(15-21)
15	11/64S40090	Screw	ネジ	2	2	2	
16	032022	Crank Shaft Connection	立ロッドメタル	1	1	1	
17	4B4×20	Screw	ネジ	4	4	4	
18	1/4S40010	Screw	ネジ	1	1	1	
19	1/4N40207	Nut	ナット	1	1	1	for DSM, 7N, 8N
20	9/32S28015	Spot Screw for 032012A, 032012B	ネジ	1	1	1	
21	9/32S28001	Screw for 032012A, 032012B	ネジ	1	1	1	
22	032041	Oil Scraper	油カキ	1	1	1	
23	11/64S40048	Screw for 032041	ネジ	1	1	1	
24	11/64N40102	Nut for 032041	ナット	1	1	1	
25	032092	Arm Rocker Shaft	上シャフト	1	-	1	
25-1	042042	Arm Rocker Shaft	上シャフト	-	1	-	
26	032101	Arm Rocker Shaft Collar	上シャフトカラー	1	1	1	(27)
27	15/64S28512	Screw for 032101	ネジ	2	2	2	
28	031161	Sprocket	サイレントスプロケット	(1)	1	-	
29	031171	Pulley	プーリー	(1)	1	-	
30	3/16S28005	Screw for 031161,031171	ネジ	(6)	6	-	
31	031191	Timing Pulley	タイミングプーリー	(1)	(1)	-	

# 06. NEEDLE BAR AND PRESSER FOOT PARTS

針棒、押工金関係

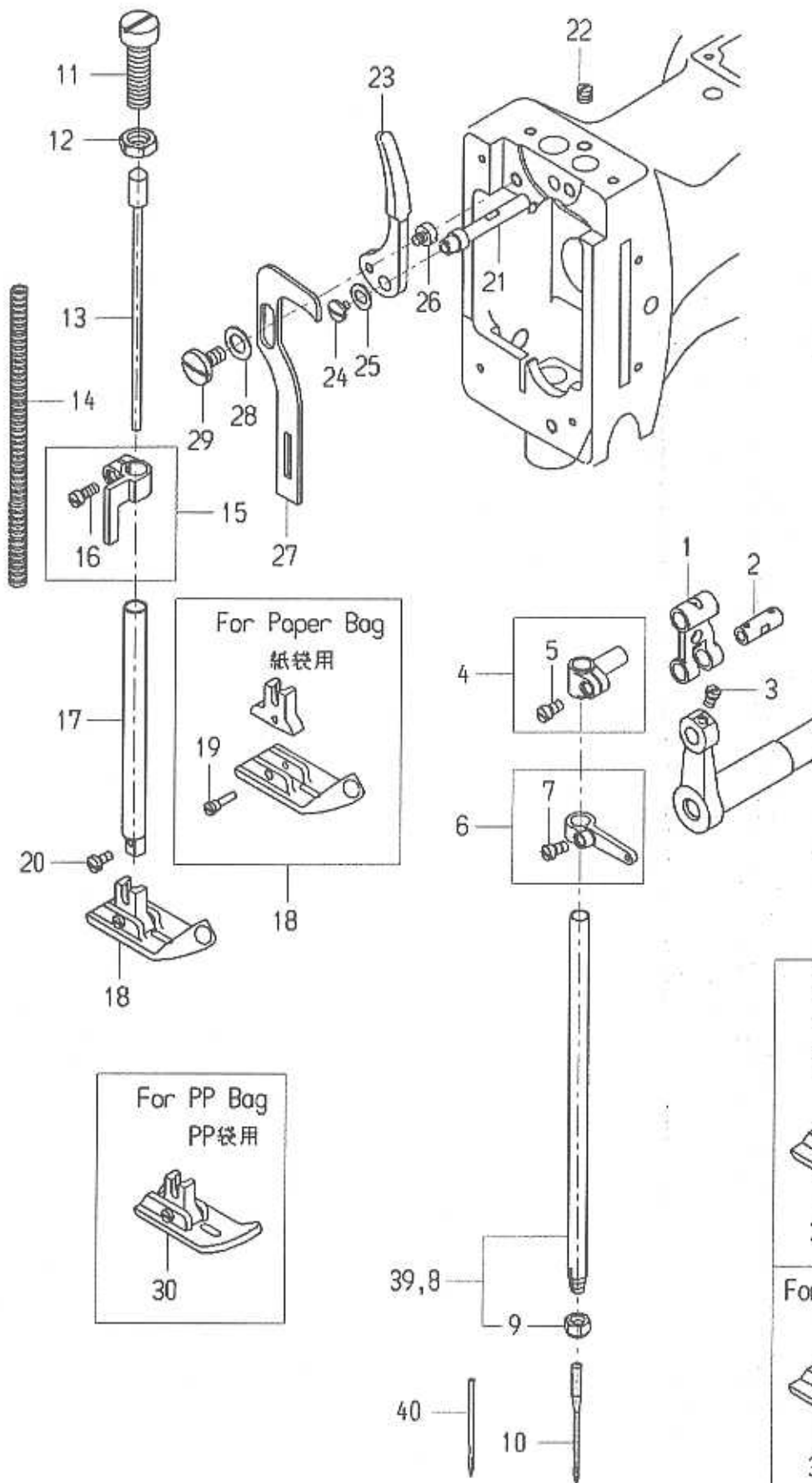

# 06. NEEDLE BAR AND PRESSER FOOT PARTS

## 針棒、押工金関係

図番 Ref. No.	部品番号 Part No.	部品名称 Description	個数 Q'ty			摘要 Remarks	
			DN-2HS	DN-2LHS	DN-2W		
1	032132	Needle Bar Link	針棒クランク	1	1	1	
2	032141	Needle Bar Link Pin	針棒クランクピン	1	1	1	
3	11/64S40076	Screw for 032141	ネジ	1	1	1	
4	032171	Needle Bar Connection	針棒抱キ	1	1	1	(5)
5	11/64S40002	Screw for 032171	ネジ	1	1	1	
6	032272	Needle Thread Take-Up	上糸天秤	1	1	1	(7)
7	11/64S40002	Screw for 032272	ネジ	1	1	1	
8	032112A	Needle Bar Ass'y	針棒組	1	1	1	(9)
9	062151	Needle Clamp Nut	針棒ナット	1	1	1	
10	B02001	Needle (DR×2 #25)	針	1	1	-	
11	032231	Presser Spring Regulator	押工調節ネジ	1	1	1	
12	3/8N28214	Nut	ナット	1	1	1	
13	032241	Presser Spring Guide	スプリングガイド	1	1	1	
14	032221	Presser Spring	押工棒スプリング	1	1	1	
15	032191	Presser Bar Connection	押工棒抱キ	1	-	1	(16)
15-1	042061	Presser Bar Connection	押工棒抱キ	-	1	-	(16)
16	11/64S40003	Screw for 032191,042061	ネジ	1	1	1	
17	032181	Presser Bar	押工棒	1	1	1	
18	012201A	Presser Foot Ass'y	押工金組	1	-	-	(19)
18-1	022081A	Presser Foot Ass'y	押工金組	-	1	-	(19)
19	11/64S40016	Screw	ネジ	1	1	1	
20	9/64S40005	Screw for Presser Foot	ネジ	1	1	1	
21	012181	Presser Foot Lifter Hinge Pin	押工揚ゲピン	1	1	1	
22	15/64S28512	Screw for 012181	ネジ	1	1	1	
23	012171	Presser Foot Lifter Lever	押工揚ゲ	1	1	1	
24	9/64S40011	Screw for 012171	ネジ	1	1	1	
25	7/32W05201	Washer for 012171	ワッシャー	1	1	1	
26	11/64S40029	Screw for 012171	ネジ	1	1	1	
27	032261	Presser Foot Lifting Link	押工揚ゲ連結桿	1	1	1	
28	5/16W05201	Washer for 032261	ワッシャー	1	1	1	
29	15/64S28017	Screw for 032261	ネジ	1	1	1	
30	012211A	Presser Foot Ass'y	押工金	(1)	-	-	(19)
30-1	022091A	Presser Foot Ass'y (PP Bag)	押工金組(PP 袋)	-	(1)	-	
31	032351	Needle Thread Take-Up	上糸天秤	-	-	1	(32)
32	11/64S40002	Screw for 032351	ネジ	-	-	1	
33	032362	Needle Holder	針ホルダー	-	-	1	
34	9/64S40002	Screw for Needle	ネジ	-	-	1	
35	9/64S40001	Screw for Needle	ネジ	-	-	1	
36	B11001	Needle (UY143GS 200)	針	-	-	2	
	B11002	Needle (UY143GS 230)	針	-	-	(2)	
37	032342A	Presser Foot Ass'y	押工金	-	-	1	(19)
38	032343A	Presser Foot Ass'y (Paper Bag)	押工金(紙袋)	-	-	(1)	(19)
39	032111A	Needle Bar Ass'y	針棒組	(1)	-	-	(9)
40	B01002	Needle (DN×1 #25)	針	(1)	-	-	

# 07. LOOPER ROCKER AND CONNECTING PARTS

## ルーパー揺動関係

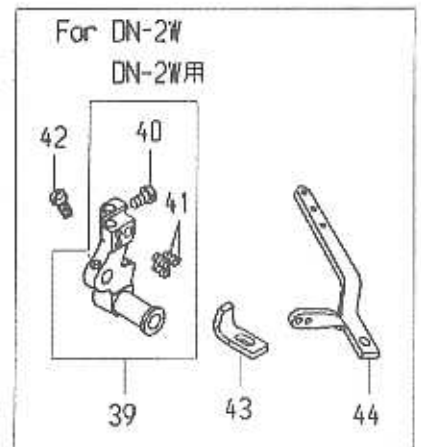
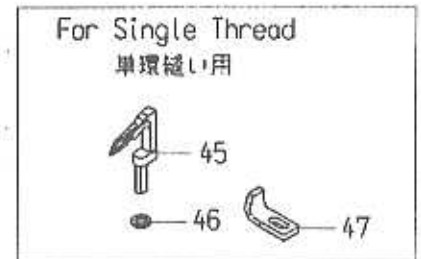
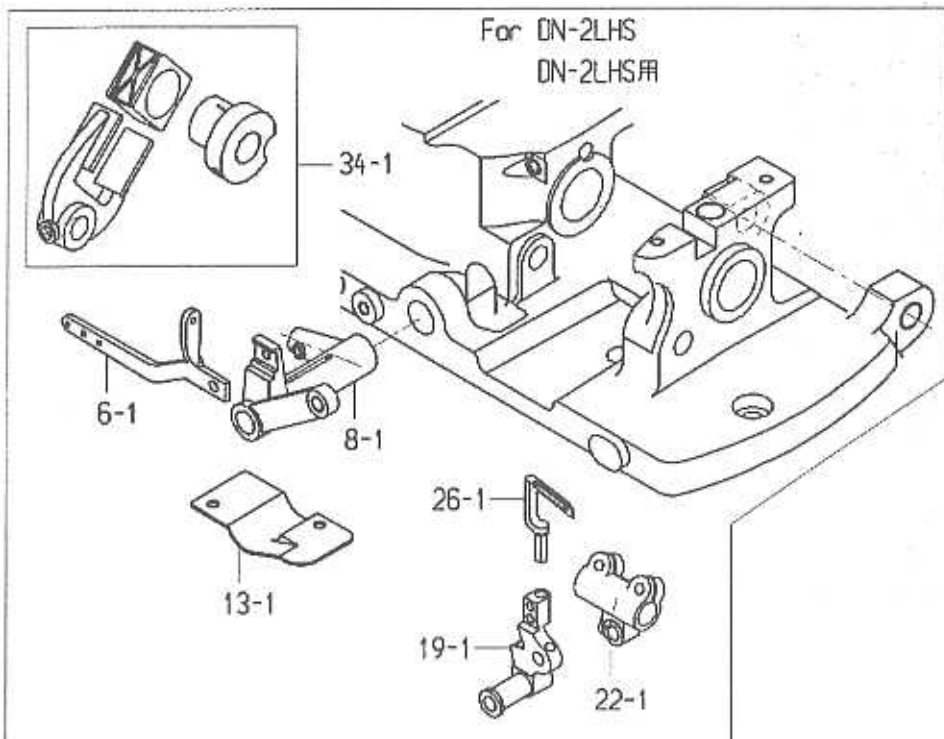
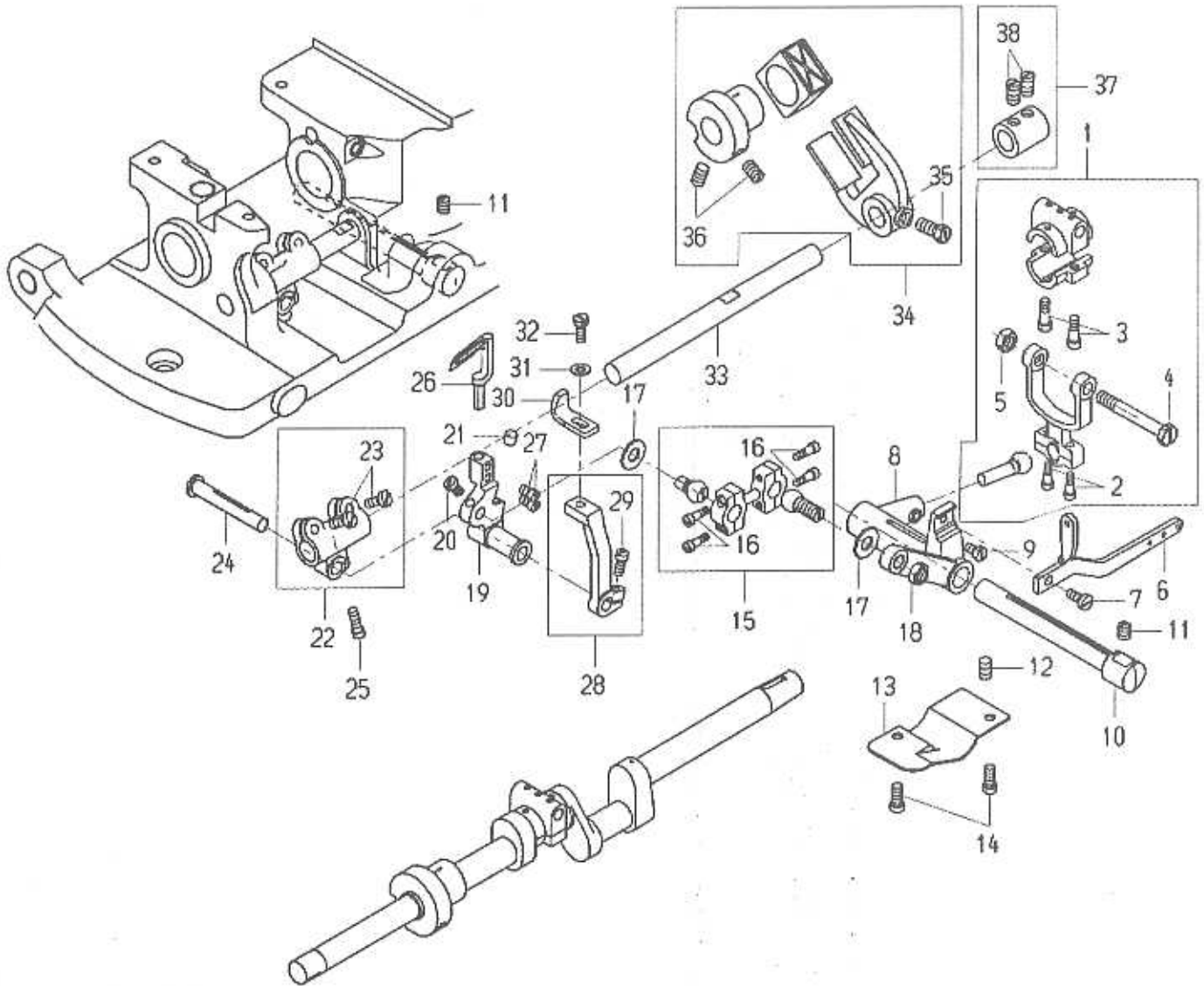

# 07. LOOPER ROCKER AND CONNECTING PARTS

## ルーパー揺動関係

図番 Ref. No.	部品番号 Part No.	部品名称 Description	個数 Q'ty			摘要 Remarks
			DN-2HS	DN-2LHS	DN-2W	
1	033022A	Looper Bell Crank Connection Rod Ass'y	1	1	1	(2-5)
2	9/64S40061	Screw	2	2	2	
3	11/64S40090	Screw	2	2	2	
4	1/4S40010	Screw	1	1	1	
5	1/4N40207	Nut	1	1	1	
6	033072	Looper Thread Take-up	1	-	-	
6-1	043081	Looper Thread Take-up	-	1	-	
7	11/64S40009	Screw for 033072, 043081	1	1	1	
8	033041	Looper Bell Crank	1	-	1	
8-1	043021	Looper Bell Crank	-	1	-	
9	11/64S40091	Screw for 033022A	1	1	1	
10	033051	Looper Bell Crank Hinge Pin	1	1	1	
11	15/64S28513	Screw for 033051	1	1	1	
12	15/64S28515	Screw for 033051	1	1	1	
13	033061	Looper Bell Crank Inside Cover	1	-	1	
13-1	043031	Looper Bell Crank Inside Cover	-	1	-	
14	3/16S28009	Screw for 033061, 043031	2	2	2	
15	033092A	Looper Connecting Rod Ass'y	1	1	1	(16)
16	9/64S40061	Screw	4	4	4	
17	9/32W10106	Washer	2	2	2	
18	9/32N28210	Nut for 033092A	1	1	1	
19	033141	Looper Carrier	1	-	-	
19-1	043061	Looper Carrier	-	1	-	
20	11/64S40005	Screw for 033092A	1	1	1	
21	245411	Felt	1	1	1	
22	033131	Looper Rocker Shaft Crank	1	-	1	(23)
22-1	043051	Looper Rocker Shaft Crank	-	1	-	(23)
23	11/64S40009	Screw for 033131, 043051	2	2	2	
24	033151	Looper carrier Hinge Pin	1	1	1	
25	11/64S40004	Screw for 033151	1	1	1	
26	033121	Looper	1	-	2	
26-1	043011	Looper	-	1	-	
27	11/64S40001	Screw for 033121, 043011	2	2	-	
28	033161	Loop Retainer Base	1	1	1	(29)
29	11/64S40003	Screw for 033161	1	1	1	
30	033171	Loop Retainer	1	1	-	
31	11/64W10101	Washer for 033171	1	1	1	
32	11/64S40049	Screw for 033171	1	1	1	
33	033183	Looper Rocker Shaft	1	1	1	
34	033201A	Looper Driving Eccentric Cam Ass'y	1	-	1	(35,36)
34-1	043071A	Looper Driving Eccentric Cam Ass'y	-	1	-	(35,36)
35	1/4S40006	Screw	1	1	1	
36	1/4S40504	Screw	2	2	2	
37	033192	Looper Rocker Shaft Collar	1	1	1	(38)
38	15/64S28007	Screw for 033192	2	2	2	
39	033312	Looper Carrier	-	-	1	(40,41)
40	9/64S40064	Screw	-	-	1	
41	9/64S40066	Screw	-	-	3	
42	11/64S40006	Screw for 033092A	-	-	1	
43	033291	Looper Retainer	-	-	1	
44	033301	Looper Thread Take-Up	-	-	1	
45	303191	Looper for Single Thread	(1)	-	-	
46	11/64W12102	Washer	(1)	-	-	
47	033172	Looper Retainer	(1)	-	-	

# 08. FEED MECHANISM DRIVING PARTS

## 送り機構関係

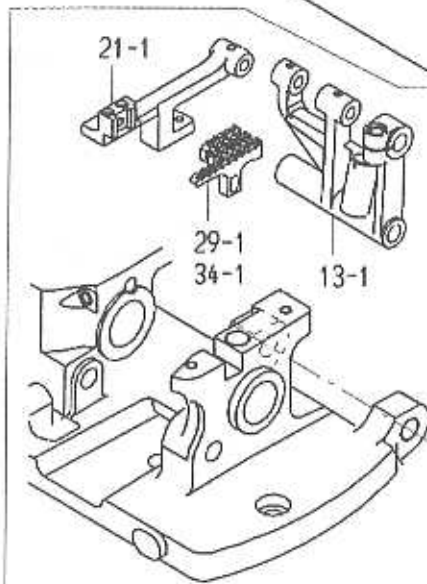
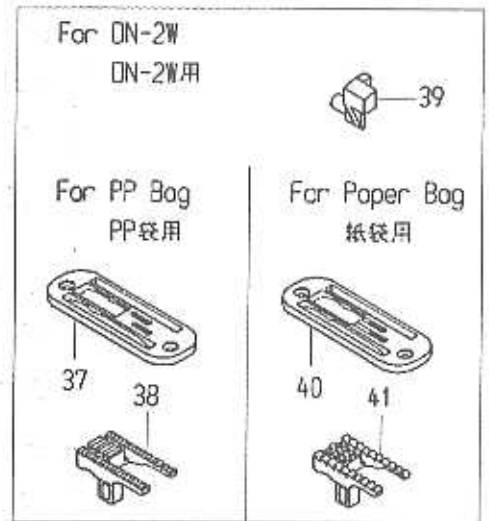
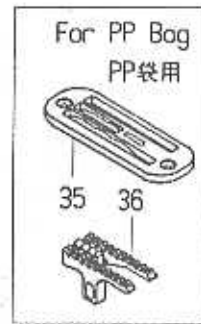
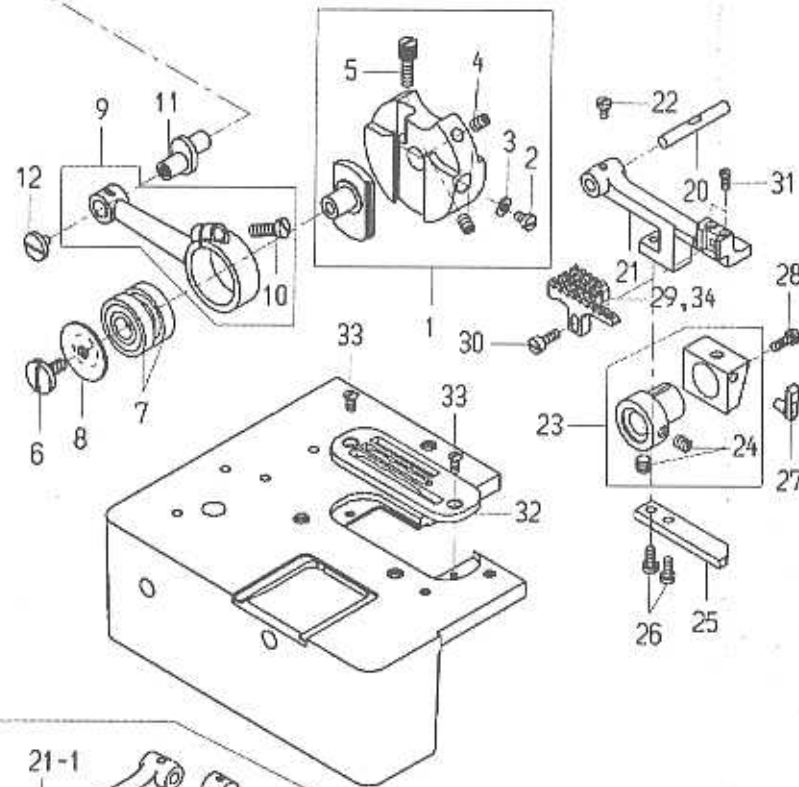
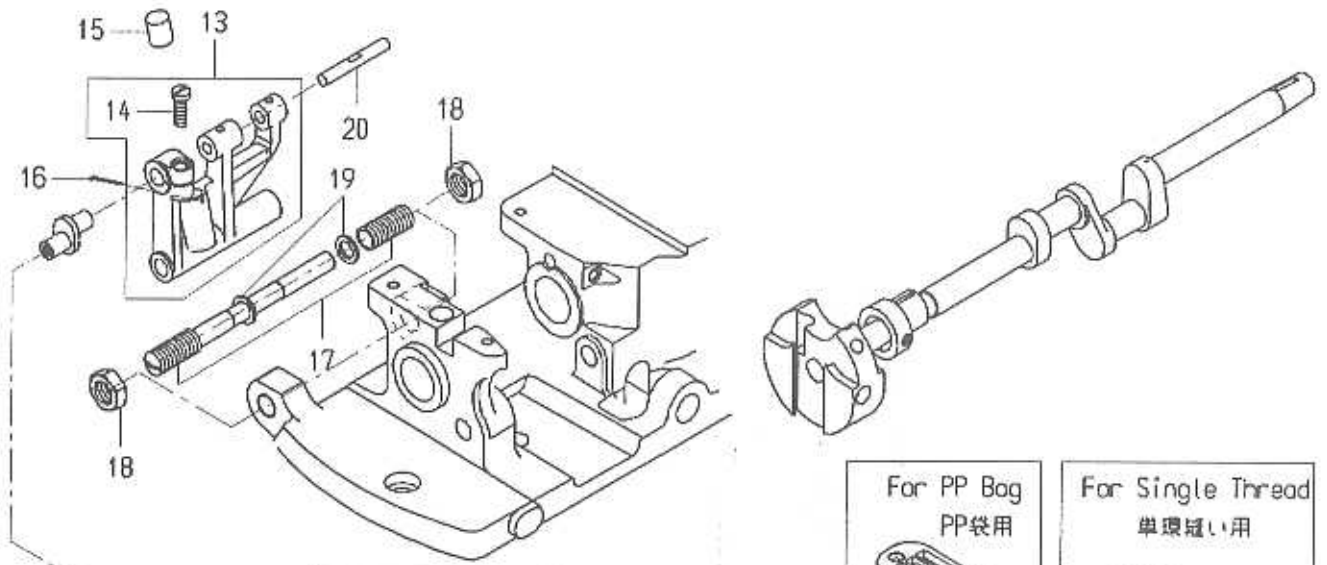

For DN-2LHS  
DN-2LHS用

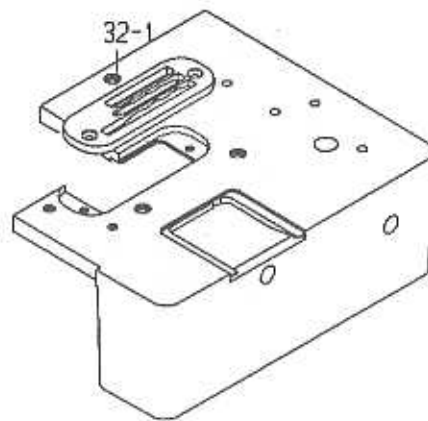
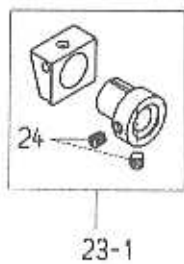

# 08. FEED MECHANISM DRIVING PARTS

## 送り機構関係

図番 Ref. No.	部品番号 Part No.	部品名称 Description	個数 Q'ty			摘要 Remarks	
			DN-2HS	DN-2LHS	DN-2W		
1	034014A	Feed Driving Eccentric Cam Ass'y	エキセンカム組	1	1	1	(2-5)
2	11/64S40057	Screw	ネジ	1	1	1	
3	11/64W10101	Washer	ワッシャー	1	1	1	
4	15/64S28526	Screw	ネジ	2	2	2	
5	7/32S32004	Screw	ネジ	1	1	1	
6	15/64S28012	Screw for 031181	ネジ	1	1	1	
7	1A01013	Ball Bearing (EN12)	自動調心ベアリング	2	2	2	
8	034111	Bearing Presser Collar	ベアリングフタ	1	1	1	
9	034032	Feed Connecting Rod	送りロッド	1	1	1	(10)
10	15/64S28002	Screw for 034032	ネジ	1	1	1	
11	034041	Feed Rocker Crank Pin	クランクピン	1	1	1	
12	11/64S40032	Screw for 034041	ネジ	1	1	1	
13	034052	Feed Rocker	送り元土台	1	-	1	(12)
13-1	044012	Feed Rocker	送り元土台	-	1	-	(12)
14	15/64S28002	Screw for 034041	ネジ	1	1	1	
15	035721	Oil Felt	給油綿	1	1	1	
16	3P1.5×20	Split Pin	ピン	1	1	1	
17	014011A	Feed Rocker Screw Shaft Ass'y	ネジシャフト組	1	1	1	
18	1/2N20216	Nut	ナット	2	2	2	
19	3/8W15108	Washer	ワッシャー	2	2	2	
20	034101	Feed Bar Shaft	送り土台ピン	1	1	1	
21	034061	Feed Bar	送り土台	1	-	1	
21-1	044041	Feed Bar	送り土台	-	1	-	
22	11/64S40005	Screw for 034061,044041	ネジ	1	1	1	
23	034091A	Feed Lift Eccentric Ass'y	送り上下組	1	-	1	(24)
23-1	044031A	Feed Lift Eccentric Ass'y	送り上下組	-	1	-	(24)
24	1/4S40503	Screw for 034091A,044031A	ネジ	2	2	2	
25	034071	Feed Bar Shoe	送り土台当板	1	1	1	
26	11/64S40009	Screw for 034071	ネジ	2	2	2	
27	034122	Needle Guide	針ガイド	1	-	-	
27-1	044052	Needle Guide	針ガイド	-	1	-	
28	11/64S40075	Screw for 034122,044052,034212	ネジ	1	1	1	
29	014311	Feed Dog	送り金	1	-	-	
29-1	024121	Feed Dog	送り金	-	1	-	
30	11/64S40048	Screw for 014311,024121,034202	ネジ	1	1	1	
31	9/64S40002	Screw for 014311,024121,034202	ネジ	1	1	1	
32	014241	Throat Plate	針板	1	-	-	
32-1	024091	Throat Plate	針板	-	1	-	
33	11/64S40007	Screw for 014241,024091,034192	ネジ	2	2	2	
34	014351	Feed Dog (Stelight)	送り金(ステライト製)	(1)	-	-	Special Order 特注
34-1	024161	Feed Dog (Stelight)	送り金(ステライト製)	-	(1)	-	
35	014221	Throat Plate, for PP Bag	針板	(1)	-	-	
35-1	024101	Feed Dog, for PP Bag	送り金	-	(1)	-	
36	014291	Feed Dog, for PP Bag	送り金	(1)	-	-	
36-1	024071	Throat Plate, for PP Bag	針板	-	(1)	-	
37	034192	Throat Plate	針板	-	-	1	
38	034202	Feed Dog	送り金	-	-	1	
39	034212	Needle Guide	針ガイド	-	-	1	
40	034193	Throat Plate, for Paper Bag	針板	-	-	(1)	
41	034203	Feed Dog, for Paper Bag	送り金	-	-	(1)	
44	014261	Throat Plate	針板	(1)	-	-	
45	014271	Throat Plate Thread Retainer	針板爪	(1)	-	-	
46	3/32S56004	Screw	ネジ	(1)	-	-	





